

4

3

2

1

PART NO. 020-01-00112

CUSTOMER DRAWING

REVISIONS			
LTR	DESCRIPTION	Drawing	DATE
A0	ease for ManufactureInitial Rel	JIANG	06/17'05
B	CHANGE THE FRAME OF DRAWING	JIANG	09/23'05

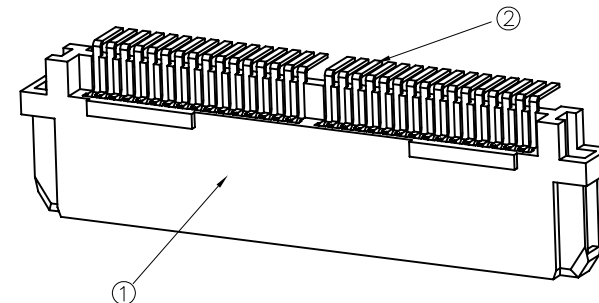
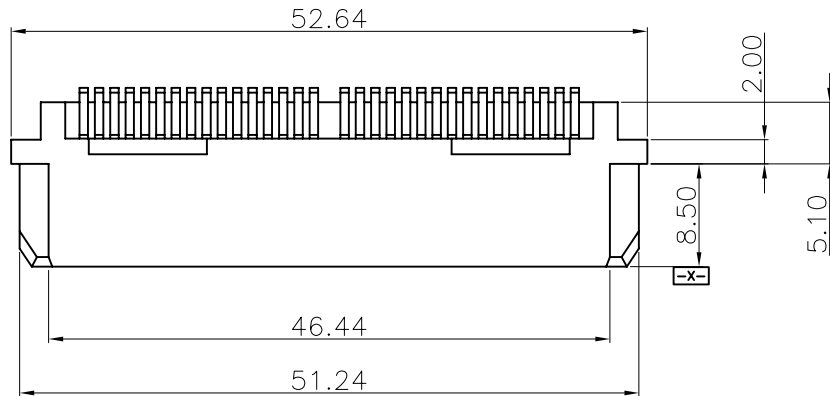

ITEM	DESCRIPTION	Q'TY	MATERIAL	FINISH
2	CONTACT	32	COPPER ALLOY	NI UNDERPLATING TIN PLATED ON SOLDER AREA GOLD PLATING ON CONTACT AREA
1	BASE	1	THERMAL PLASTIC	COLOR:BLACK

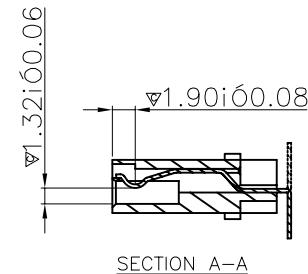
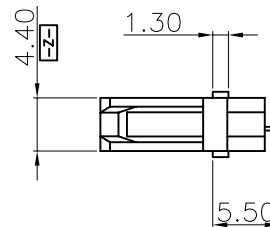
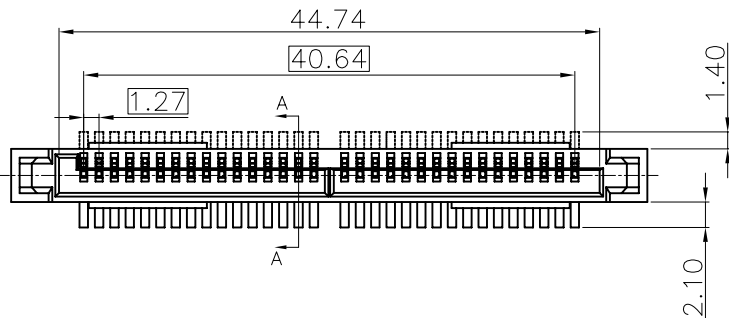

NOTES:

- MATERIAL:
HOUSING: LCP UL94V-0, COLOR: BLACK
CONTACT: COPPY ALLOY.
- FINISH:
CONTACT: GOLD PLATING ON CONTACT AREAS;
TIN PLATED ON SOLDER TAILS;
NICKEL UNDERPLATE OVER ALL.
- THE MARK ∇ DIMENSIONS MUST BE CONTROLLED BY QC.
- PRODUCT SPECIFICATION REFERENCE TO *****.
- PACKAGING SPECIFICATION REFERENCE TO *****.

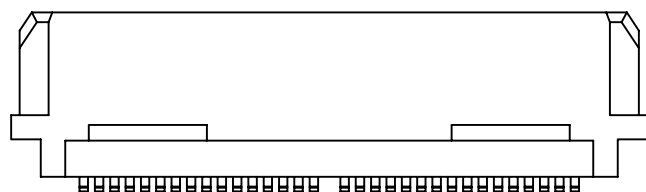

DIMENSION ARE MILLIMETERS TOLERANCES ARE : DECIMALS .X i ϕ 0.30 .XX i ϕ 0.25 ANGLE: X \pm 1°	APPROVALS		DATE	PART NO. 020-01-00112
	DRAWN	JIANG	09/23'05	
	CHECKED			TITLE: SAS CABLE 32P(FEMALE) R/A TYPE(FOR SHELL) CUSTOMER DRAWING
	APPROVALS			SIZE mm SCALE : 1 : 1 DRAWING NO. 000233 REV. B
ID NO.	XXXXXXXXXX	SHEET 1 OF 1		

DESCRIPTION

4

3

2

1

NO

Q'TY UNIT

DO NOT SCALE DRAWING

ID NO.

XXXXXXXXXX

SHEET 1 OF 1