

DIM. E=(A+3.5)±0.10

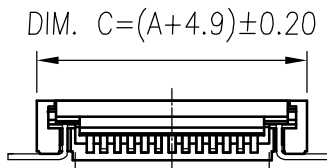

DIM. B=(A+2.1)±0.05

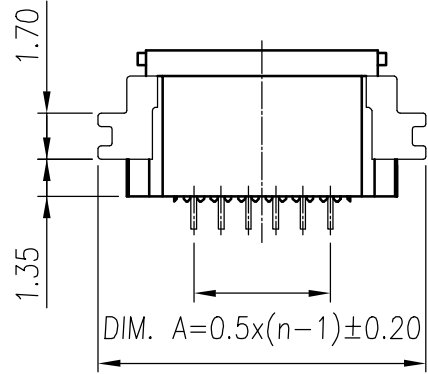

DIM. D=(A+7)±0.20

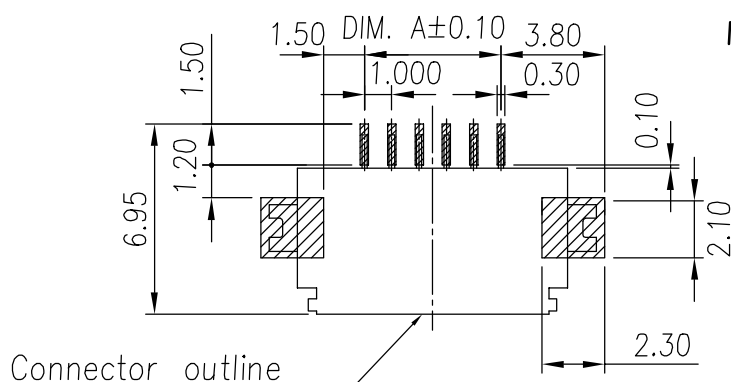

Connector outline

RECOMMENDED PCB LAYOUT  
TOLERANCE: ±0.05

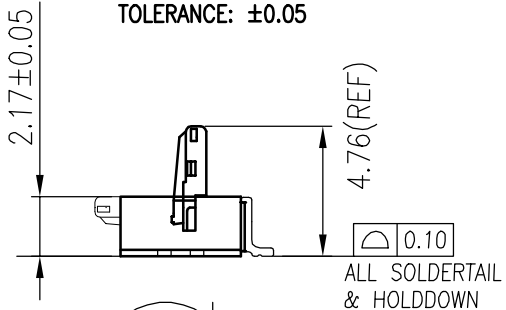

ALL SOLDER TAIL & HOLDDOWN

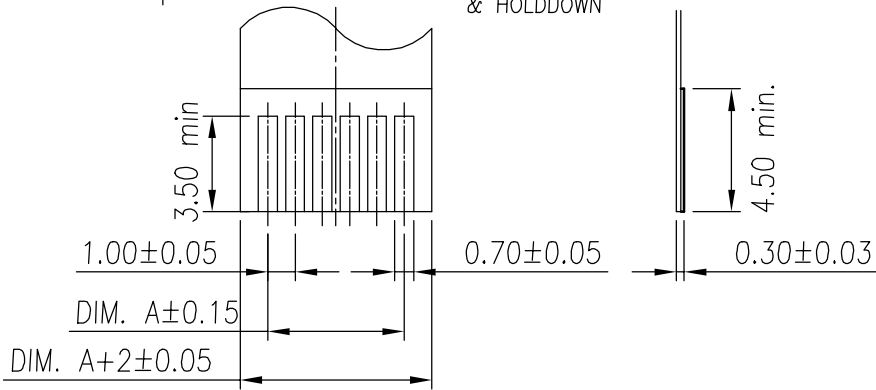

Applicable FPC/FFC recommended dimension

NOTE:

MATERIAL:  
HOUSING: HIGH TEMPERATURE THERMOPLASTIC.  
COVER: HIGH TEMPERATURE THERMOPLASTIC.  
CONTACT: COPPER ALLOY.  
PLATING: TIN, LEAD FREE OR GOLD OVER NICKEL.  
HOLDDOWN: COPPER ALLOY.  
PLATING: TIN, LEAD FREE OVER NICKEL  
PRODUCT SPECIFICATION: PS-FPC-04  
PACKAGING SPECIFICATION: REEL: FP1204001

PART NO.

FP224 - XX 4 X 4  
          Ⓐ       Ⓑ

- Ⓐ XX : NO. OF CONTACTS 04 - 39PIN
- Ⓑ X : PLATING
- M : TERMINAL AND HOLDDOWN ALL TIN, LEAD FREE (MATTED)
- GM : TERMINAL GOLD 1u" , HOLDDOWN TIN, LEAD FREE (MATTED)

				TOLERANCE				TITLE: FFC/FPC 1.0 PITCH CONNECTOR , ZIF SMT TYPE , BODY HIGH 2.00 mm.					
				LINEAR	ANGLES			PART NO. FP224-XX4X4					
				X±0.30	X'±	APPD:	Jason	MAT'L:	DWG NO. FP2207001				
B	09043	Willson	Nov,03,2009	.X±0.20	.X'±	CHKD:	Schumi	FINISH:		UNITS	SCALE	SHEET	REV
A	08028	Terry	May,07,2008	.XX±0.15	.XX'±	DRWN:	Willson	Q'TY:		MM	1 : 1	1 OF 2	B
REV	ECN NO.	NAME	DATE	.XXX±0.08	.XXX'±								

Pin	Dimension					Pin	Dimension				
	A	B	C	D	E		A	B	C	D	E
4	3.00	5.10	7.90	10.00	6.50	24	23.00	25.10	27.90	30.00	26.50
5	4.00	6.10	8.90	11.00	7.50	25	24.00	26.10	28.90	31.00	27.50
6	5.00	7.10	9.90	12.00	8.50	26	25.00	27.10	29.90	32.00	28.50
7	6.00	8.10	10.90	13.00	9.50	27	26.00	28.10	30.90	33.00	29.50
8	7.00	9.10	11.90	14.00	10.50	28	27.00	29.10	31.90	34.00	30.50
9	8.00	10.10	12.90	15.00	11.50	29	28.00	30.10	32.90	35.00	31.50
10	9.00	11.10	13.90	16.00	12.50	30	29.00	31.10	33.90	36.00	32.50
11	10.00	12.10	14.90	17.00	13.50	31	30.00	32.10	34.90	37.00	33.50
12	11.00	13.10	15.90	18.00	14.50	32	31.00	33.10	35.90	38.00	34.50
13	12.00	14.10	16.90	19.00	15.50	33	32.00	34.10	36.90	39.00	35.50
14	13.00	15.10	17.90	20.00	16.50	34	33.00	35.10	37.90	40.00	36.50
15	14.00	16.10	18.90	21.00	17.50	35	34.00	36.10	38.90	41.00	37.50
16	15.00	17.10	19.90	22.00	18.50	36	35.00	37.10	39.90	42.00	38.50
17	16.00	18.10	20.90	23.00	19.50	37	36.00	38.10	40.90	43.00	39.50
18	17.00	19.10	21.90	24.00	20.50	38	37.00	39.10	41.90	44.00	40.50
19	18.00	20.10	22.90	25.00	21.50	39	38.00	40.10	42.90	45.00	41.50
20	19.00	21.10	23.90	26.00	22.50						
21	20.00	22.10	24.90	27.00	23.50						
22	21.00	23.10	25.90	28.00	24.50						
23	22.00	24.10	26.90	29.00	25.50						

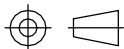
				TOLERANCE				TITLE: FFC/FPC 1.0 PITCH CONNECTOR , ZIF SMT TYPE , BODY HIGH 2.00 mm.				
				LINEAR	ANGLES			PART NO. FP224-XX4X4				
				X±0.30	X'±	APPD: Jason		MAT'L:				
	See Sheet 1			.XX±0.15	.XX'±	CHKD: Schumi		FINISH:				
REV	ECN NO.	NAME	DATE	.XXX±0.08	.XXX'±	DRWN: Willson		Q'TY:				
									UNITS	SCALE	SHEET	REV
								MM	1 : 1	2 OF 2	B	