

SECTION A-A

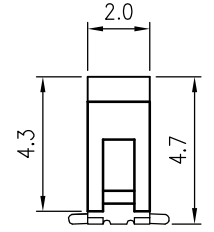

NO. OF CONTACTS
4 PIN~14 PIN

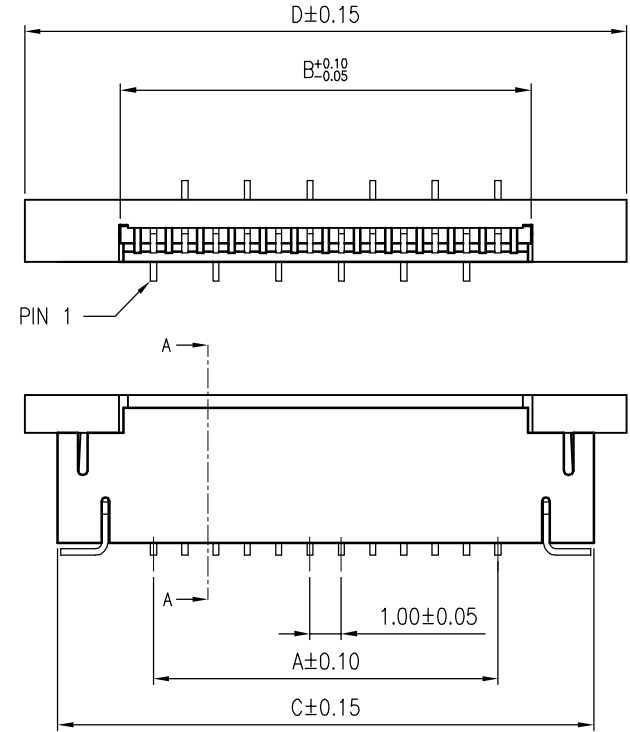
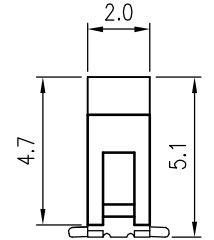

NO. OF CONTACTS
15 PIN~30 PIN

■ MATERIAL
 HOUSING: HIGH-TEMP.
 ACTUATOR: HIGH-TEMP.
 CONTACT: PHOSPHOR BRONZE. PLATING: ALL TIN, LEAD FREE.
 HOLDDOWN: BRASS. PLATING: ALL TIN, LEAD FREE.
 CAP: BRASS. PLATING: Ni.

■ ELECTRICAL
 VOLTAGE: 50V MAX.
 CURRENT: 0.5A MAX.
 DIELECTRIC WITHSTANDING VOLTAGE: 250 VAC.
 INSULATION RESISTANCE: 50 MEGAOHMS MIN.
 CONTACT RESISTANCE: 20 MILLIOHMS MAX.

■ ENVIRONMENTAL
 TEMPERATURE RANGE: -20°C TO 85°C.

■ FEATURE AND SPECIFICATIONS
 SIZES 04 TO 30 PIN.
 FOR 0.3mm THICKNESS FFC/FPC.

- PART NO.**
- | | | | | | | |
|----|---|---|---|---|----|---|
| FZ | 2 | 2 | X | - | XX | X |
| ① | ② | ③ | ④ | | ⑤ | ⑥ |
- ① FZ : FPC ZIF SMT SERIES
 - ② 2 : 1.0 mm PITCH
 - ③ 2 : BODY WIDTH 2.0 mm
 - ④ X : TYPE
 - 1: TOP ENTRY , NORMAL TYPE (ALL TIN, LEAD FREE)
 - 5: TOP ENTRY , NORMAL TYPE (ALL Gold 1u")
 - ⑤ XX : NO. OF CONTACTS 04 - 30 PIN
 - ⑥ X : PACKING
 - 2: TUBE
 - 3: CAP & TUBE
 - 4: REEL
 - 5: CAP & REEL

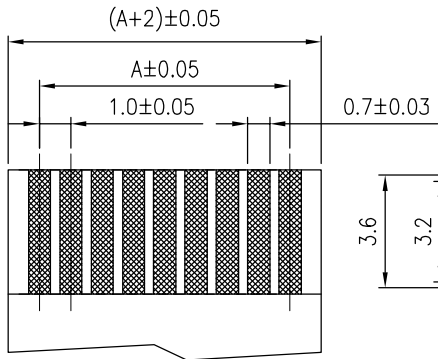

FFC/FPC DIMENSION
THICKNESS 0.30 mm

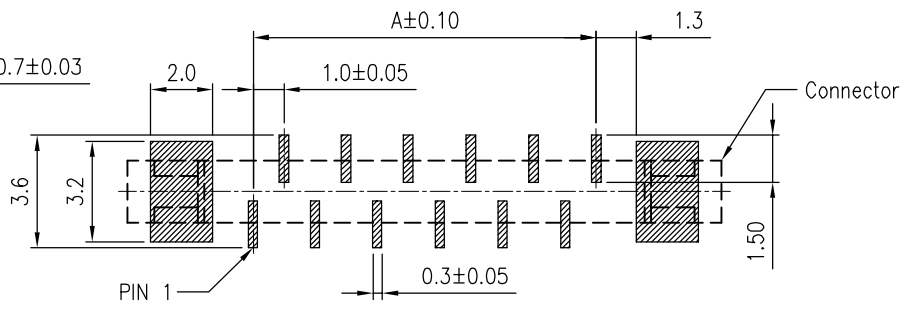

RECOMMENDED PCB LAYOUT

TOP ENTRY , NORMAL TYPE

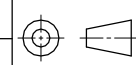

				TOLERANCE				TITLE: FPC/FFC 1.0 PITCH CONNECTOR , ZIF SMT TYPE BODY WIDTH 2.0 mm									
F	E	D	C	REV	ECN NO.	NAME	DATE	.XXX±0.05	.XXX*±	APPD:	MAT'L:	DWG NO.	UNITS	SCALE	SHEET	REV	
						Willson	May.08.2006	LINEAR	ANGLES								
						Willson	Jan.05.2006	X.±0.20	X*.±								
						Willson	Aug.02.2005	.X±0.15	.X*±	APPD:	Jason						
						Willson	May.11.2005	.XX±0.10	.XX*±	CHKD:	Schumi	FINISH:					
						Willson				DRWN:	Willson	Q'TY:					



UNITS	SCALE	SHEET	REV
MM	1 : 1	1 OF 5	F

■ DIMENSION TABLE

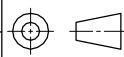
Circuits	Dimension				
	A	B	C	D	E
4	3.00	5.10	9.10	11.10	10.40
5	4.00	6.10	10.10	12.10	11.40
6	5.00	7.10	11.10	13.10	12.40
7	6.00	8.10	12.10	14.10	13.40
8	7.00	9.10	13.10	15.10	14.40
9	8.00	10.10	14.10	16.10	15.40
10	9.00	11.10	15.10	17.10	16.40
11	10.00	12.10	16.10	18.10	17.40
12	11.00	13.10	17.10	19.10	18.40
13	12.00	14.10	18.10	20.10	19.40
14	13.00	15.10	19.10	21.10	20.40
15	14.00	16.10	20.10	22.10	21.40
16	15.00	17.10	21.10	23.10	22.40
17	16.00	18.10	22.10	24.10	23.40
18	17.00	19.10	23.10	25.10	24.40
19	18.00	20.10	24.10	26.10	25.40
20	19.00	21.10	25.10	27.10	26.40
21	20.00	22.10	26.10	28.10	27.40
22	21.00	23.10	27.10	29.10	28.40
23	22.00	24.10	28.10	30.10	29.40
24	23.00	25.10	29.10	31.10	30.40
25	24.00	26.10	30.10	32.10	31.40
26	25.00	27.10	31.10	33.10	32.40
27	26.00	28.10	32.10	34.10	33.40
28	27.00	29.10	33.10	35.10	34.40
29	28.00	30.10	34.10	36.10	35.40
30	29.00	31.10	35.10	37.10	36.40

				TOLERANCE				TITLE: FPC/FPC 1.0 PITCH CONNECTOR , ZIF SMT TYPE BODY HIGH(WIDTH) 2.0 mm					
				LINEAR	ANGLES			PART NO. FZ22X-XXX					
				X.±0.20	X'±	APPD:	Jason	MAT'L:	DWG NO. FZ1207				
				.X±0.15	.X'±	CHKD:	Schumi	FINISH:		UNITS	SCALE	SHEET	REV
F		Willson	May.08.2006	.XX±0.10	.XX'±	DRWN:	Willson	Q'TY:		MM	1 : 1	5 OF 5	D
REV	ECN NO.	NAME	DATE	.XXX±0.05	.XXX'±								